

# The Imaging Source Helpdesk

知识库 > FAQ > Electrical Connection of Strobe and GP Out

## Electrical Connection of Strobe and GP Out

S.Geißler - 2020-11-26 - FAQ

The electrical connection of the strobe and GP Out is Open Drain MOSFET. In very simply words, they work like a switch. Therefore, there is no square wave or other signal to measure.

Please use a pull-up resistor to connect this output to Vcc (max. 24 VDC). Please note that the max drain current is 200 mA:

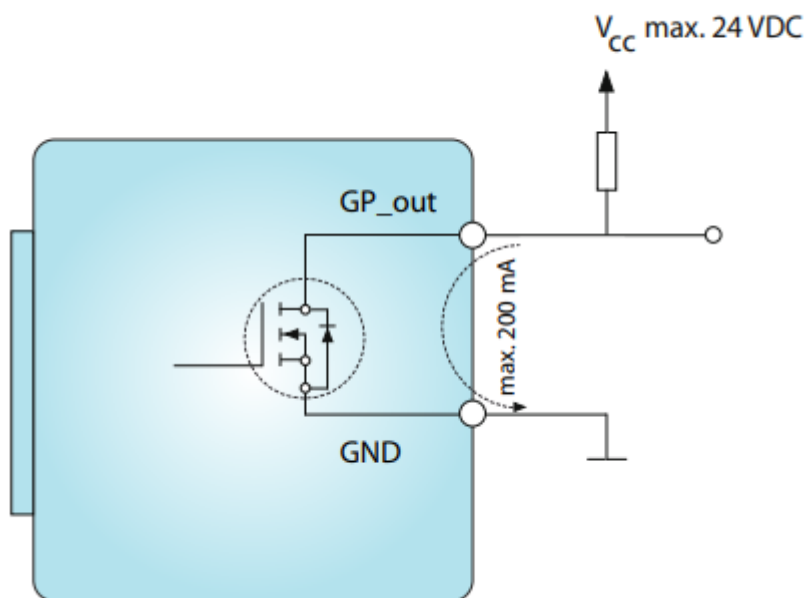

The pin assignment of a camera can be found in [Industrial Cameras: 23/33/Z12/Z30 Series - Trigger and I/O](#) on Page 7.

The pin assignment of the 33U,37U,38U, 33G,37G,38G series can be found in the Technical Reference Manuals at the cameras under "Documentation" tab too.

A sample connection is also:

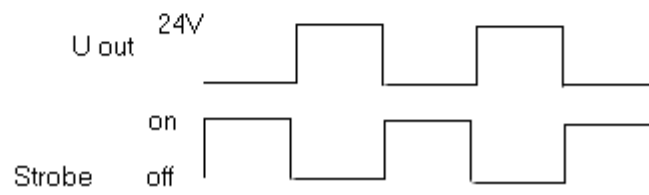
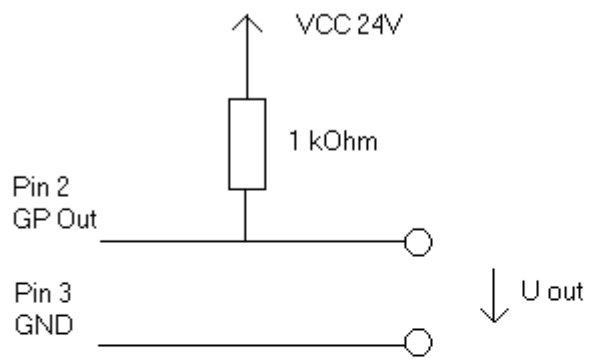

The pin numbers can be different at the camera model you use. The "U out" to "Strobe on off" relation depends on strobe polarity, if available on your camera.